



egeplast

egeplast

HexelOne® SLM

High-pressure pipe system made of PE with additional protective layer

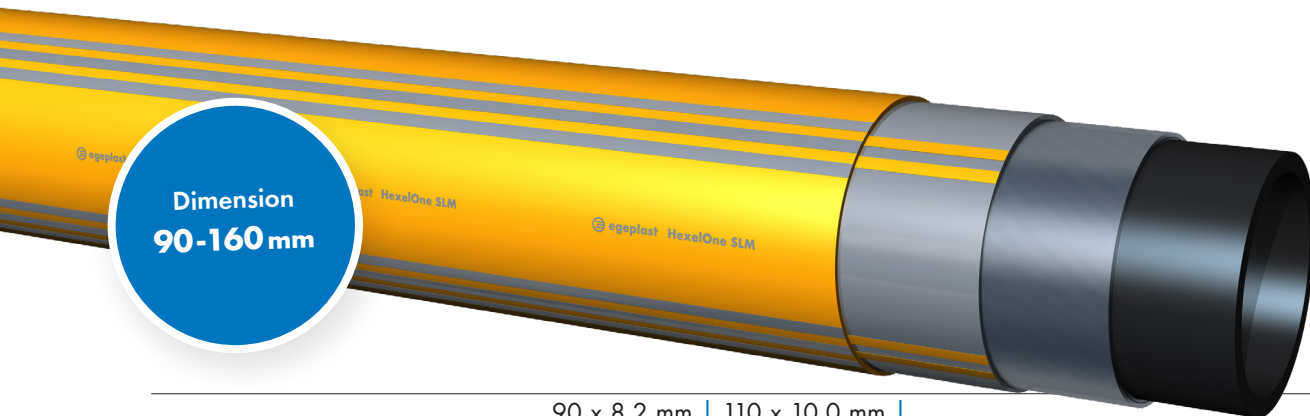

Dimension	90 x 8.2 mm 110 x 10.0 mm 125 x 11.4 mm 160 x 14.6 mm
Pipe design	Pipe dimensions in accordance with DIN 8074
Application	Gas
Material	Medium pipe: PE 100 / PE 100-RC Protective layer: Polyolefin
Features	DVGW-certified Also suitable for trenchless installation thanks to protective layer and interior layer made of PE 100-RC Combination of DVS-compliant welding methods: Butt welding and electrofusion welding 100 percent recyclable
Marking	Meter marking / Colour-coding for different media
Delivery forms	Sticks of 6 or 12 m Coiled bundles / drums of 100 m Other lengths on request
Product standards	DIN 8074 DVGW GW 335-A5
Tests and certification	TÜV SÜD MUC-KSP-A3005 DVGW
Regulations / Installation- and processing guidelines	DVGW GW 320 GW 321 GW 323 G 472 G 469 GW 332 DVS 2207-1 DIN EN 12007 DIN 4124 egeplast Processing Guidelines
Services and Support	Clamping jaws Protective layer peeling devices Compression tools Processing equipment Instructions at the construction site Project planning Site monitoring



Created: 08.12.2022 JK

Checked: 08.12.2022 JK

Approval: 08.12.2022 JK

Version: 1.0

This datasheet is for information purposes only. egeplast accepts no guarantee with respect to the up-to-dateness, accuracy and completeness of the information. egeplast reserves the right to revise and supplement this document without prior notice.

egeplast international GmbH

Robert-Bosch-Straße 7 • 48268 Greven • Tel. +49 2575 9710-0 • Fax +49 2575 9710-110 • info@egeplast.de • www.egeplast.de

