



egeplast

egeplast

egeLiner

Folding pipe system for trenchless pipe rehabilitation

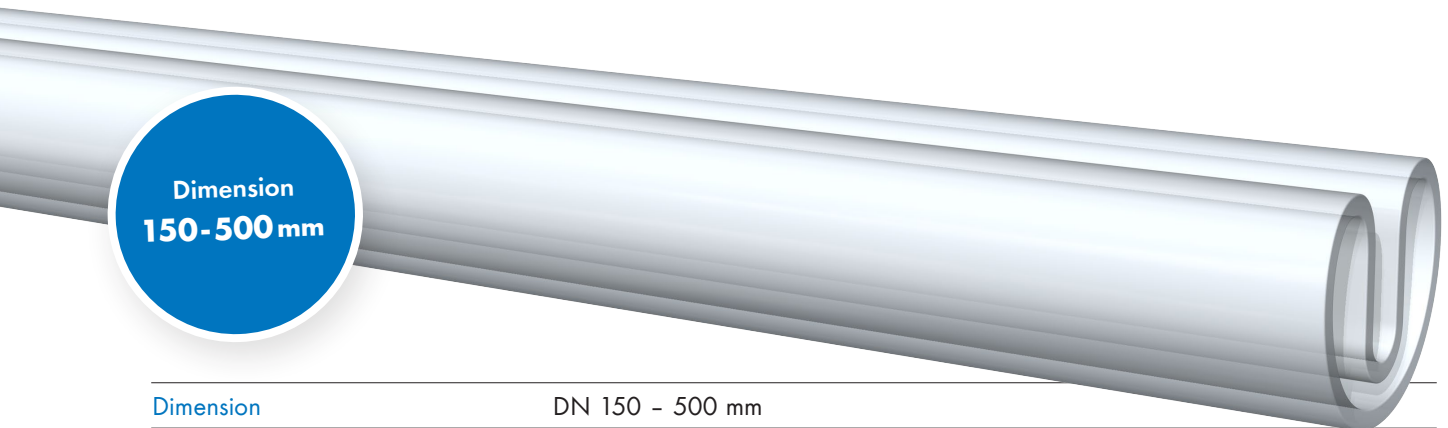

Dimension	DN 150 - 500 mm
SDR rating	SDR 26, SDR 17 (DN 500 in SDR 21 only)
Application	Sewage Unpressurized applications Trenchless pipe deformation methods (Close-fit)
Material	PE 100, PE 100-RT
Pipe design	Pipe string with thermomechanically deformed cross-section
Features	Low space requirements at the construction site Short rehabilitation times and low amount of civil engineering works Low cross section reduction - Close-fit Enhanced flow characteristics owing to reduced roughness of the pipe walls
Colour	Natural colour Opak
Delivery forms	Drum
Regulations / Installation- and processing guidelines	In accordance with DIN EN ISO 11296

Created: 29.07.2025 JK

Checked: 29.07.2025 JK

Approval: 29.07.2025 JK

Version: 1.1

This datasheet is for information purposes only. egeplast accepts no guarantee with respect to the up-to-dateness, accuracy and completeness of the information. egeplast reserves the right to revise and supplement this document without prior notice.

egeplast international GmbH

Robert-Bosch-Straße 7 • 48268 Greven • Tel. +49 2575 9710-0 • Fax +49 2575 9710-110 • info@egeplast.de • www.egeplast.de

